

ABone Progress & Status Report

Active Nets PI Meeting, Teton Village, WY
June 6, 2001

Bob Braden (ISI), Steve Dawson (SRI)

*Steve Berson, Craig Milo Rogers, Yu He, Siva Jayaraman
(ISI)
Fred Gilham
(SRI)*



The ABone is...

- A testbed for active networking
- Composed of diverse OS platforms distributed across many organizations.
- Executes multiple Execution Environments (EEs).
- Overlaid on the Internet, but also includes some other testbeds (CAIRN, Emulab)
- Monitored by ABone Coordination Center ([ABOCC](#)).



Why Build an ABone?

(Instead of many private AN testbeds?)

- Realistic heterogeneity
- Realistic networking issues
- Non-trivial scale
- Foster collaboration
- Develop common components towards larger goal
- Share burdens of tool development and software maintenance.
- Repository for useful EEs and AAs
- Platform for teaching



Outline: Progress & Status Report

- Brief Overview of ABone architecture
- Progress and Status
 - ABoneShell
 - Management and Monitoring
 - Netiod
 - ABone users
- Anetd V1 & V2 (Steve Dawson, SRI)
- The ABone in the Xbone (Yushun Wang, ISI)
- Future Directions

Review ABone Architecture

- Locally-administered OS platforms: Linux, FreeBSD, Solaris (root password is private).
- **Core** nodes always available; **edge** nodes come/go.
- On core nodes: EEs are remotely managed using **Anetd** and **ABoneShell**.
 - Execute in user mode.
 - Install, restart, kill, configure, debug, monitor EEs.
- “Permanent” EEs: always available for AA developers.
- Variety of network I/O modes

ABone Heterogeneity





- Nodes
 - Registered: 77 nodes
 - Configured & reachable: 57+ nodes
 - Anetd 1.6.7 stable: ~47 nodes
- Operating System releases
 - Linux 2.2, 2.4
 - FreeBSDs 3.4, 3.5, 4.1, 4.2
 - Solaris: 5.5, 5.6, 5.7, 5.8
 - AMP NodeOS: ?
- Permanent EE topologies (*“virtual active networks”*)
 - ASP EE versions: 1.3.2 (21 nodes), 1.4+ (4 nodes)
 - ANTS EE versions: 1.3.1 (6 nodes), 2.0 (6 nodes)

See ABone Web page: www.isi.edu/abone

Monitor the Whole ABone

Registered ABone Nodes

UCW	DAL	UALBER	UIORO	BBN	amp1.cs.tat.com	SRID1	SRID2	SRID3	SRID9	SRidr	ISIabs
FOKUS	COLUMB	ISIdad	ISHub	ISlon	KENT	PRINCE	UCLache	UCLaur	UKANS1	UKANS2	UKYdu
UKYman	UKYsar	UMASS	UPENNn	UPENNn	UPENNn	USC	UIAhpca	WASH	HCRLAa	HCRLA	HCRLAz
LORLA	NIS1bla	NIS1blu	NIS1gre	NIS1red	NIS1yel	CNR	KWANGW	AHRL	BBNpc	ISlpc	ISlpc2
ISlpc3	ISlpc	ISlpc2	LBLpc	SRlpc	ISlpc	ISlpc	pc1.emulab.net	pc10.emulab.net	pc2.emulab.net	pc3.emulab.net	pc4.emulab.net
pc5.emulab.net	pc6.emulab.net	pc7.emulab.net	pc8.emulab.net	pc9.emulab.net	ABROeegr	ABRObran	ABROgram	ABROslgm	ABROslgn	ABROslgu	ABROvois
MITANE1	OVERblu	OVERred	NOUIW	GATECH							

Suspend	Reload	SaveCoord	Table
 Unknown status			
 No Response			
 ICMP Ping OK, but no ANetD response			
 ANetD is running but denying access			
 ANetD is running and responding correctly			

Registered ABone Nodes: Status Summary

Status report generated at 23:34:54 GMT on 29-May-2001 (16:34:54 PDT)

Node Name	OS	Version	IP/ICMP Echo (Ping)	anpub	abocc	anee1	anee2	anee3	anee4	anee5
pushkin.abone.uow.edu.au	linux	2.4.0-test11	Up	Up	Up	Up	Up	Up	Up	Up
nemain.cs.dal.ca	linux	2.2.16	Up	Up	Up	Up	Up	Up	Up	Up
newby.cs.ualberta.ca			Down	Down	Down	Down	Down	Down	Down	Down
abone.nal.utoronto.ca			Down	Down	Down	Down	Down	Down	Down	Down
core-abone-bos1.bbn.com	linux	2.4.2-2	Up	Up	Up	Down	Up	Up	Up	Up
amp1.csl.sri.com	exos		Down	Down	Down	Down	Down	Down	Down	Down
d01.csl.sri.com	bsd44	4.2-RELEASE	Down	Down	Up	Up	Up	Up	Up	Up
d02.csl.sri.com	bsd44	3.4-RELEASE	Down	Up	Up	Up	Up	Up	Up	Up
d03.csl.sri.com	linux	2.2.14-5.0	Down	Up	Up	Up	Up	Up	Up	Up
d05.csl.sri.com	linux	2.2.14-5.0	Down	Up	Up	Up	Up	Up	Up	Up
sirius.csl.sri.com	solaris	5.7	Down	Up	Up	Up	Up	Up	Up	Up
active.netsec.tislabs.com	linux		Up	Up	Up	Up	Up	Up	Up	Up
abone.fokus.gmd.de	linux		Up	Up	Up	Up	Up	Up	Up	Up
view.cs.columbia.edu	linux	2.2.18pre20	Up	Up	Up	Up	Up	Up	Up	Up
dad.isi.edu	linux	2.2.16-3	Up	Up	Up	Up	Up	Up	Up	Up
hub.isi.edu	solaris	5.6	Up	Up	Up	Up	Up	Up	Up	Up
son.isi.edu	bsd44	4.1.1-RELEASE	Up	Up	Up	Up	Up	Up	Up	Up
oahu.medianet.kent.edu			Down	Down	Down	Down	Down	Down	Down	Down

Registered ABone Nodes: Java

Status report generated at 23:45:33 GMT on 29-May-2001

Node Name	OS	Version	anpub	abocc	aneel	
pushkin.abone.uow.edu.au	linux	2.4.0-test11	jdk1.1.8 jdk1.2.2	jdk1.1.8 jdk1.2.2	jdk1.1.8 jdk1.2.2	jdk
nemain.cs.dal.ca	linux	2.2.16	No JDKs available	No JDKs available	No JDKs available	No
newby.cs.ualberta.ca						
abone.nal.utoronto.ca						
core-abone-bos1.bbn.com	linux	2.4.2-2	jdk1.1.7 jdk1.2.2	jdk1.1.7 jdk1.2.2	jdk1.1.7 jdk1.2.2	jdk
amp1.csl.sri.com	exos		jdk1.1	jdk1.1		jdk
d01.csl.sri.com	bsd44	4.2-RELEASE				
d02.csl.sri.com	bsd44	3.4-RELEASE				
d03.csl.sri.com	linux	2.2.14-5.0				
d05.csl.sri.com	linux	2.2.14-5.0	jdk1.1.8_v1 jdk1.2.2 jdk1.3.0	jdk1.1.8_v1 jdk1.2.2 jdk1.3.0	jdk1.1.8_v1 jdk1.2.2 jdk1.3.0	jdk jdk
sirius.csl.sri.com	solaris	5.7	jdk1.1.8 jdk1.2.2 jdk1.3.0	jdk1.1.8 jdk1.2.2 jdk1.3.0	jdk1.1.8 jdk1.2.2 jdk1.3.0	jdk jdk
active.netsec.tislabs.com	linux		jdk118_v1	jdk118_v1	jdk118_v1	jdk
abone.fokus.gmd.de	linux		No JDKs available	No JDKs available	jdk1.3.0	No
view.cs.columbia.edu	linux	2.2.18pre20	jdk1.1.8	jdk1.1.8 jdk1.2.2	jdk1.1.8	jdk
dad.isi.edu	linux	2.2.16-3	jdk1.1.8	jdk1.2.2 jdk1.1.8	jdk1.2.2 jdk1.1.8	jdk
hub.isi.edu	solaris	5.6	jdk11x jdk12x	jdk11x jdk12x	jdk11x jdk12x	jdk
son.isi.edu	bsd44	4.1.1-RELEASE	jdk1.2.2 jdk1.1.8	jdk1.2.2 jdk1.1.8	jdk1.2.2 jdk1.1.8 jdk1.2.2-ants	jdk

Active Nets Daemon (anetd) V1

- Management Software for the ABone
 - Client (sc) and server code (anetd)
 - Initiate EEs
 - Upload/Download files
 - Query node, Anetd, and EE status
- NodeOS functions
 - Packet forwarding

ABOCC -- ABone Coord'n Center

- Email: abocc@isi.edu
- Web pages <http://www.isi.edu/abone>
(Hyperlinked to SRI Web pages)
- Registration of users, nodes
- Installing new Anetd versions
- Asking node administrators for help...
- Working with users
- Building monitoring and configuration tools
- ...

Node Security

- OS must be secure against code introduced by Anetd
 - NOT an option: cannot allow downloading arbitrary untrusted EE code
- Anetd client signs commands, and server gets public key from local ACL file.
 - o ACL=> what principal may execute Anetd commands under what account(s)?
 - o TCL=> code server from which EEs can be loaded
- ABOCC controls ACL, TCL entries
- Restarting Anetd reloads ACL, TCL.

ABone Accounts

7 accounts on every node, for security partitioning:

- ~abocc: access to Anetd code, ACL, TCL, and JVM config
- ~anpub: all who register at (SRI) Web site
- ~anee1: EE developers for trusted Java EEs (ASP and ANTS)
- ~anee2: Assigned to PLAN (UPenn)
- ~anee3: Assigned to ENHANTS (TASC)
- ~anee4: unassigned
- ~anee5: ABOCC experimental

Each account has Anetd process, ACL file, and TCL file.



Node security (cont'd)

- Security from evil EE or EE developer: not perfect.
- Java sandboxing helps a lot.
- Anetd installs its own Security Manager for all Java-based Ees. Each EE must install SM Extension to further restrict actions of its AAs.



Progress: since Portland PI Meeting

- (a) Anetd V1: Continued evolution [SRI: Dawson]
- (b) New registry mechanism [SRI: Dawson]
- (c) ABoneShell: management tool & user interface [ISI]
- (d) ABone monitoring improved [ISI, SRI]
- (e) Anetd V2: Design and development
 - ABCd: Abone Control daemon [SRI: Dawson]
 - netiod: network I/O daemon [ISI]
- (f) ABone under Xbone [ISI:Wang]
- (g) Helping users [ISI, SRI]

ABone Meeting @ ISI: 21 Feb 2001

Attended: ISI, SRI, Aerospace, BBN, NAI, U Ky, U Wash

Agenda:

- Anetd: Status & Plans: Steve Dawson, SRI
- The ABOCC Registry System: Fred Gilham, SRI
- ASP EE Status: Bob Lindell, ISI
- ANTS EE Status: Andrew Whitaker, U Wash
- AMP NodeOS Status: Steve Schwab, NAI
- Concast for the Abone: Mary Bond, U Ky
- Network I/O Daemon (netiod): Steve Berson, ISI
- Deploying Abone using Xbone: Yushun Wang & Joe Touch, ISI
- Security in the Abone: Bob Lindell, ISI
- The Sencomm Project: James Sterbenz, BBN

ABoneShell

- Active Network Management tool
- Interactive front end to Anetd client
- Two kinds of functions:
 - (1) Higher-level user interface for Anetd operations on EEs.
 - (2) Use Anetd to invoke management **EElets**
- Shell-like scripting facilities
 - Can be driven from command files
 - Allows subroutines

ABoneShell Components

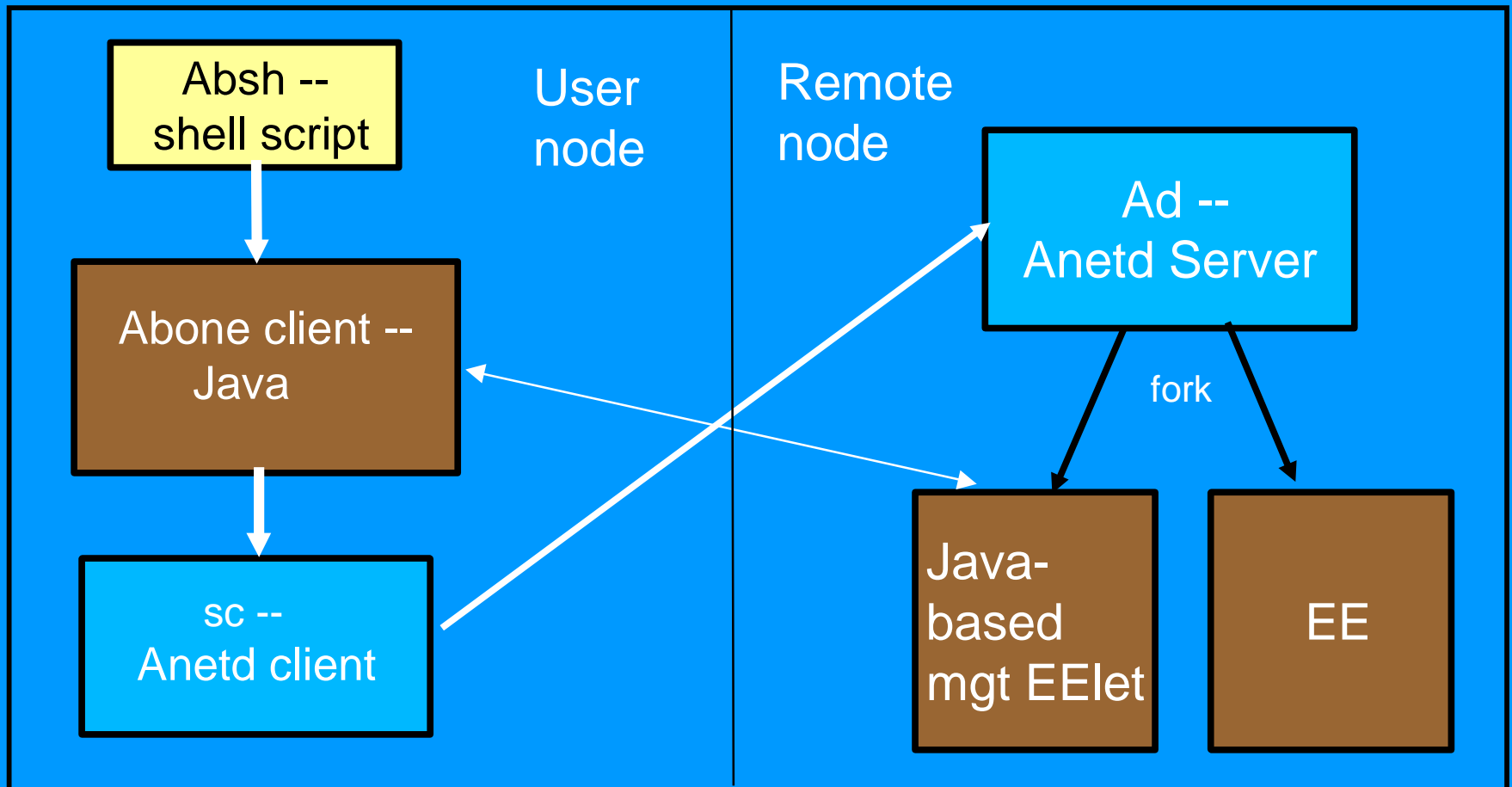

ABoneShell Commands

- Commands on remote file system
 - *ls, cd, pwd, dir, copy, delete, rename, mkdir*
- File transfer & compare commands
 - *put, get, compare*
- Remote system status commands
 - *hostname, netstat[-a|-i|-r], printenv, ps, uname, killpid*
- Control commands
 - *reinit anetd, restart anetd (=> kill EEs) , sighup-all-nodes*
- Misc commands
 - Test for (*stealth*) firewall blockage



Management

- As input to the discussion of network management for active networks, last year we presented a list of useful management variables.
- The following 3 slides repeat that list and show what progress the ACTIVATE project has made in implementing these variables.



Management Variables (1)

- Node management
 - Liveness and connectivity (ICMP 'ping')
 - RTT measurement ('ping')
 - CPU resources ('ps')
 - File system ('ls')
 - Routing ('netstat')
 - Traffic control (queue lengths)
 - Retrieve SYSLOG (if protection OK)
 - Retrieve an EE log file

Abone Shell	Web Monitor
Yes	Yes
Yes	Yes
Yes	No
Yes	No
Yes	No
n/a	n/a
Yes*	No
Yes	No

Management Variables (2)

- Anetd management
 - Per account: UDP port, version, account.
 - Liveness/Uptime
 - Per account and started EE:
 - o Name, up time, TypeID, permanent/not
 - o Packet counts
 - Retrieve Anetd or EE log file
 - Force restart of running Anetd (& running EEs)
 - Restart EE

Abone Shell	Web Monitor
Yes	Yes
Yes	Yes
Yes	Yes
No	No
Yes	No
Yes	No
Yes*	No

Management Variables (3)

- EE management

- Version (date, number...)
- Uptime
- Liveness
- RTT measurements (virtual topology)
- List of loaded AAs
- per loaded AA: name, uptime, resources
- Virtual topology and virtual<->real mapping
- Query virtual routing table
- Virtual traffic control (queue lengths)
- Halt/reload (privileged)

ANTS	ASP
No	Yes
No	Yes
Yes	Yes
Yes	Yes
No	Yes
No	Yes*
No	Yes
No	Yes
n/a	n/a
Yes	Yes

{ANTS & ASP} EE Monitoring

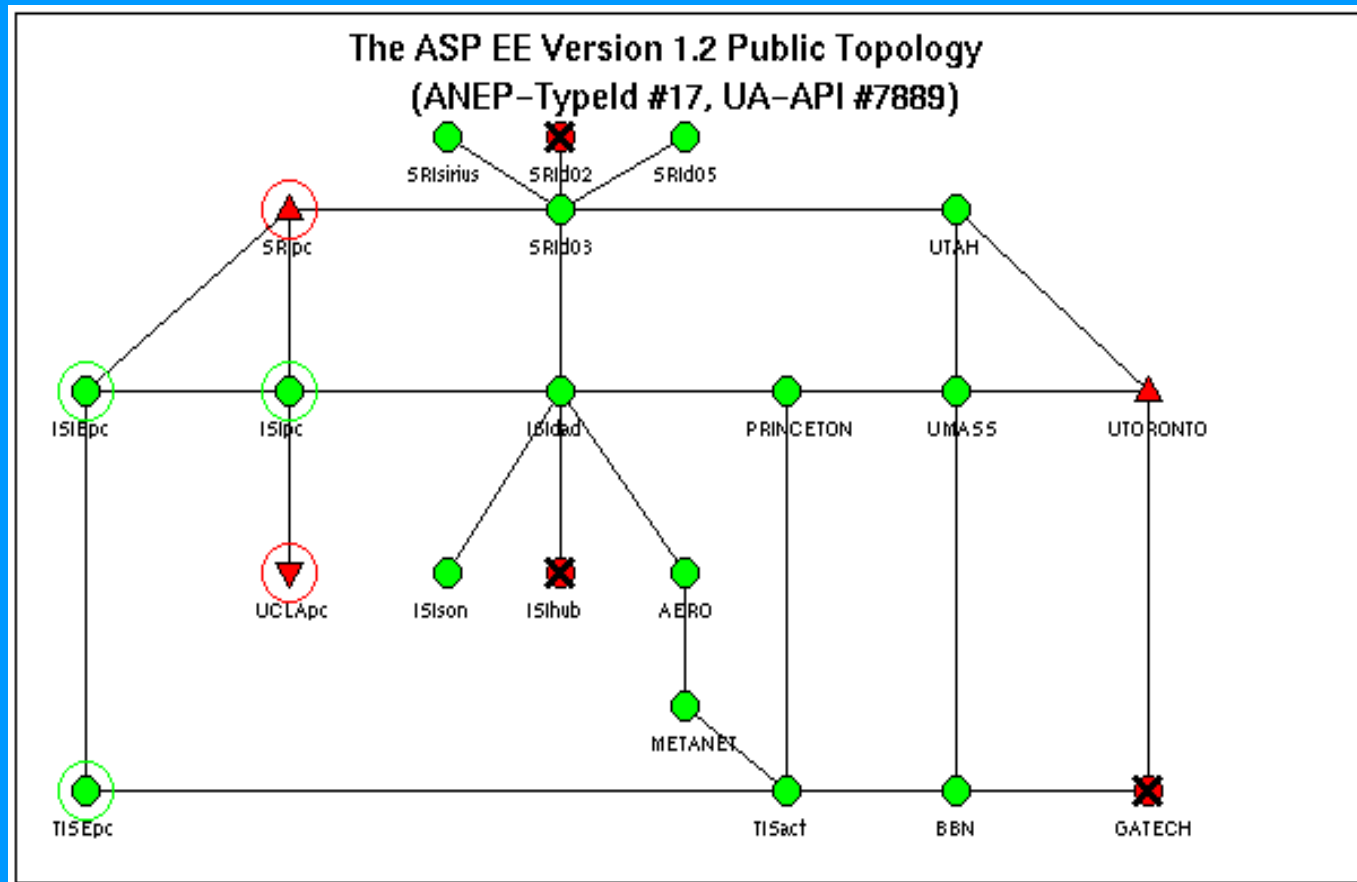

Anetd v2

- Anetd 1 -> ABCd + netiod (for Unix)
 - ABCd - ABone Control daemon
 - EE management functions of Anetd
 - Redesigned for easier maintenance and installation
 - Steve Dawson will talk about it
 - Netiod - Network I/O daemon
 - Handles network I/O for Unix platforms
 - Runs as root
 - NodeOS channel interface to EEs

Netiod and ABCd

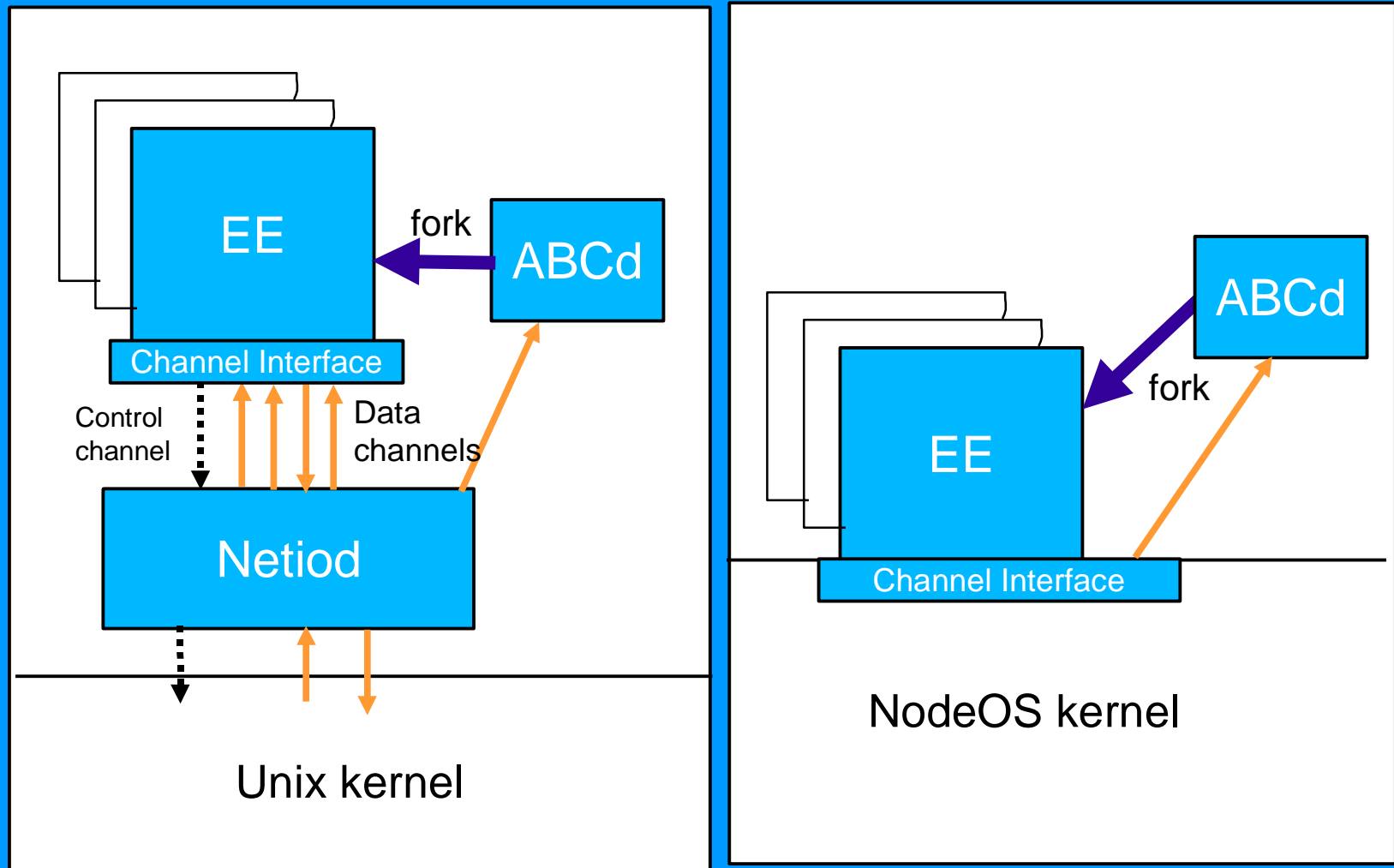

Netiod Objectives

- Unix implementation of network I/O for EEs
- Support FreeBSD, Linux, and (eventually) Solaris
- EE interface compatible with nodeOS channel abstraction
 - {ProtocolSpec, AddressSpec, DemuxKey} triple
 - Flexible packet capture for input
- Hide OS differences from EEs
 - Each OS (version) has different kernel hooks for filtering and diverting packets
- (None or) minimal kernel changes

Network I/O Modes

- Virtual connectivity (ANTS & ASP)
 - UDP tunnels, per-EE virtual topology & network address space.
 - To EE: “if/ipv4/UDP”, demux(ANEP typeid)
- Native IP connectivity (ASP soon)
 - Running in the Internet ‘porridge’ with real IP addresses.
 - To EE: “if/ipv4”, demux(IP proto ID, etc.)
- Link-Layer Connectivity
 - To EE: “if”
- Virtual native IP connectivity (Xbone)
 - “if/ipv4/ipv4/esh-ipsec/ipv4” -> “if/ipv4”

ABone Users

- TASC/ISI/NAI -- Active Filter Signaling & MoDSAF, Demo 2000
AFSP AA / ASP EE
- TASC (Diane Kiwior) -- Active Reliable Multicast, Demo 2000
- BBN Sencomm Project -- Network Management (ongoing)
- Aerospace Corp. -- Active Filter Signaling testbed (ongoing)
- Univ Kentucky (Mary Bond) -- Concast (planned)
- AMP nodeOS (soon!)
- Univ Kentucky, Ga Tech: CANES EE (pending)
- USC grad students (ongoing)

Student Users

- USC Graduate DR class on Active Networking
 - Prof. Cauligi (“Raghu”) Raghavendra (USC CS & Aerospace)
- 9 students, 7 projects; 2 tried to make working code.
 - IPv4 <-> IPv6 Translation (=> working Java code)
 - Echoplex (ASP EE, ABone) (Got it working in ABone)
- ABOCC gave lectures, helped students
- Lessons:
 - Our introductory documentation needs improvement!
 - Hope for more progress in continuation, summer 2001.



Future ABoneTasks

- Anetd v2 (ABCd & netiod) development
- Usability improvements
- Install more EEs
- Install more nodeOS's
- Xbone integration
- Scheduling & auto-configuration of nodes
- Active networks security
- Development of AN debugging tools



Bold Research Idea that is Less Successful Than We Hoped...

- The ABone... How are we doing?
 - In building initial infrastructure and software base?
 - Pretty well.
 - In making the ABone easy to use?
 - Not so well, yet.
 - In building a user community?
 - Not well at all!
- Responses:
 - Usability effort planned
 - USC grad students
 - Shame more EE developers into ABone installation



(Shaky -- cont)

- Inadequate diagnostic & management
 - Difficult to know why remote ABone software was failing
 - Many system variables: OS, JVM, Anetd version, Anet bugs, EE versions, EE bugs, mis-configured nodes.
- Response: ABoneShell and SENCOMM.



ABone Issues

- Regular [mbone/phone] conferences of Abone users?
- Usability
 - Better documentation
 - Debugging facilities
 - Topology generation
- Security: (thou shalt...)
- How much experiment concurrency will actually be possible?
 - Possible ABone usage models:
 - Static public topology => some nodes down [*current model*]
 - Dynamically configured, private topologies, scheduling.
- [How] can ABone support loadable kernel modules?



Issue: Integration of Node OSs

- [To what extent] can EEs be portable across Node OSs and Unix/Anetd?
- E.g.: EEs written to Node OS spec; in Unix, run on shim layer that maps Posix into Node OS interface?
 - Probably limitations -- how severe?
 - E.g., implementation of general packet filtering semantics of Node OS may require kernel changes in Linux and/or FreeBSD.
- Accept limitations of Unix systems vs. modify kernels ?



Issue: Debugging AAs and EEs

- Overlaps with network management
- EE debugging
 - Exec EE under jdb/gdb on each node [done]
 - Pipe stdout back to client
- AA debugging
 - Harder, in general: debugging distributed algorithms
 - May need both code breakpoints and “packet breakpoints”
(*Sequester* input packets in EE or in channel, release manually).
 - Another technique: *active probes*

Issue: Active Network Management

- We mean both parsings of the title above.
- Want to use active network techniques for ABone mgt.
 - Active nets => don't need protocol standards;
active NM should => don't need MIB standards.

[“Free us from the tyranny of the MIB and ASN.1!”]
 - Active traps (currently called “probes” at ISI): code that monitors specific state in node, sends spontaneous or periodic msgs.
Needs some design work.
- Need standard instrumentation interfaces

ANEP Issues

- Include remote (IP addr, UDP port) so EE can distinguish pt-pt virtual links in packet received via Anetd.

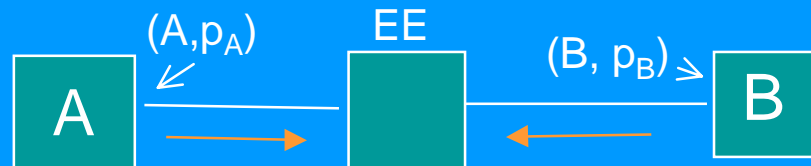

- SANEP or ANEP: include security extensions?
- Is ANEP really a new network header? If not, what are src & dest address options for?
- If not Layer 3, is it Layer 2.5, 3.5, or 4.5?
- Need AflowID, for efficient demux to AA with node OS interface.
- Time to define ANEP v2?? (*Hack or fundamental?*)