

# Using Active Networks To Improve Feedback Congestion Control (ACC)

Ted Faber

USC/ISI  
faber@isi.edu

## Active Networks (AN)

- Active Network: A Programmable Network
  - Number of Programmable Elements
  - Time Scale
- In the Limit...
  - Each Network Element Programmable
  - Each Packet a Program (Capsules)

## Outline

- Active Networking
- Feedback Congestion Control
- Active Congestion Control (ACC)
- ACC Simulations And Implementation Status

## AN Example (Video Transcoding)

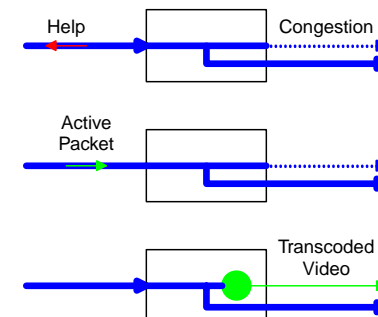



## Uses of AN

---

- Dynamic Router Code Updates
- Management And Monitoring
- Service Migration
- New Services INside The Net



## Where Does ACC Fit?

---

- Assume:
  - CPU Cycles On Routers And Access with AN
  - Access To Router State (Queue Lengths)
  - Simple Programmability
- Can We Improve Feedback Congestion Control?  
(Yes, or I'd be at home...)



## Challenges of AN

---

- Security - Can It Be Done Safely/Fairly?
- Efficiency - Can It Be Done Quickly?
- Applicability - Is It Worth Doing?
  - Active Congestion Control (ACC)



## Feedback Congestion Control

---

- Iteratively Search For A Good Operating Point
  - Make A Change
  - See How The System Changes
  - Observation Determines The Next Change
- TCP Sender...
  - Changes Window Size
  - Checks For Loss Each Round Trip Time
  - If Loss, Reduce Window To 1/2 Current
  - No Loss, Increase Window By 1 Packet



## More TCP Congestion Control

---

- Additive Increase/Multiplicative Decrease
  - Probes Slowly For Additional Capacity
  - Allows Router To Drain After Overflow
- Loss Is Deduced – No Direct Feedback
  - Timeout
  - Successive Same ACKs



## Some TCP Optimizations

---

- Slow-Start
  - Oscillation Control
- Fast Retransmission
  - Oscillation Control
- Random Early Drop (RED) Queueing
  - Signal Quality
- Explicit Congestion Notification (ECN)
  - Signal Quality
- TCP Vegas
  - Signal Quality



## Feedback Shortcomings

---

- Congestion Signal
- Oscillation Control
- Bandwidth-Delay Product



## ACC: Bandwidth-Delay Product

---

- Use Router Intelligence To Reduce Congestion
- Routers Calculate Endpoint Responses
- Nearby Routers Implement Local Response
- Source Eventually Recalibrates
- Reverse the Lag



## Method Comparison

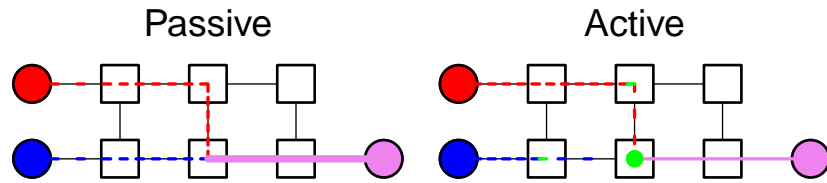

- Infers Congestion
- Endpoint Response

- Detects Congestion
- Router Response



## Simulation Studies (Topology)

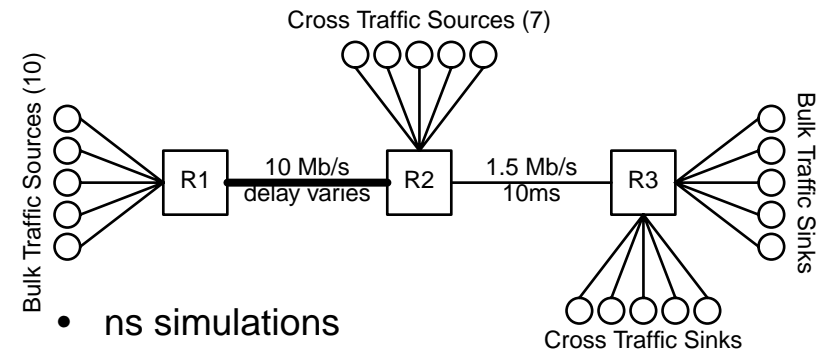

- ns simulations
- Compare ACC to TCP in high BW-Delay
- Bursty Traffic



## Simulation Studies (Algorithm)

- ACC for TCP:
  - Routers Initiate Correction On Packet Drop (Routers Use RED)
  - Packets Are Filtered On Arrival (Simulates Upstream Drop)
  - Corrections Calculated From Extra Packet Info (Current Congestion Window In Header)
  - Source Modifies Behavior To Match Feedback (Source Matches Router Calculation)



Throughput vs. RTT (Std. Dev. bars)

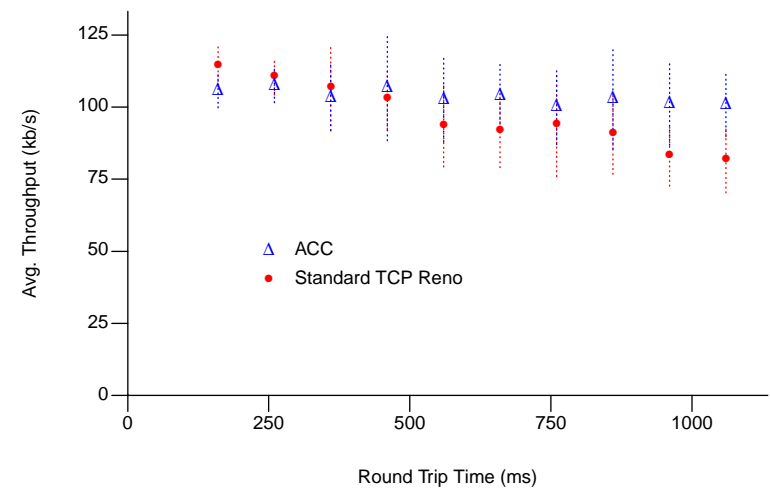

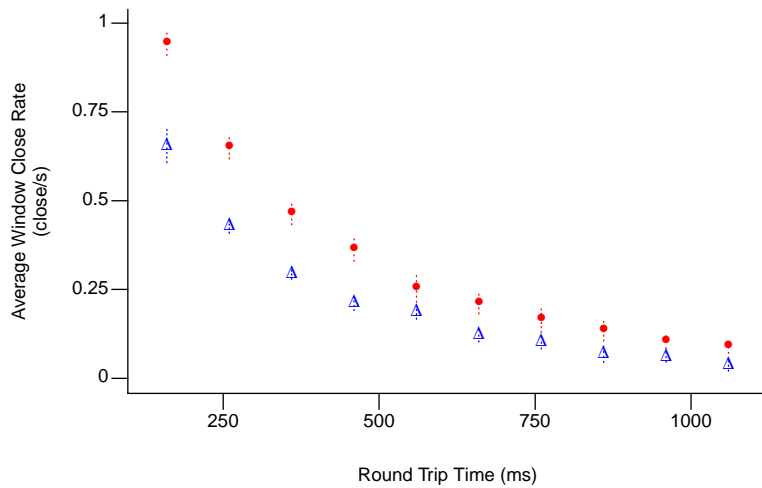
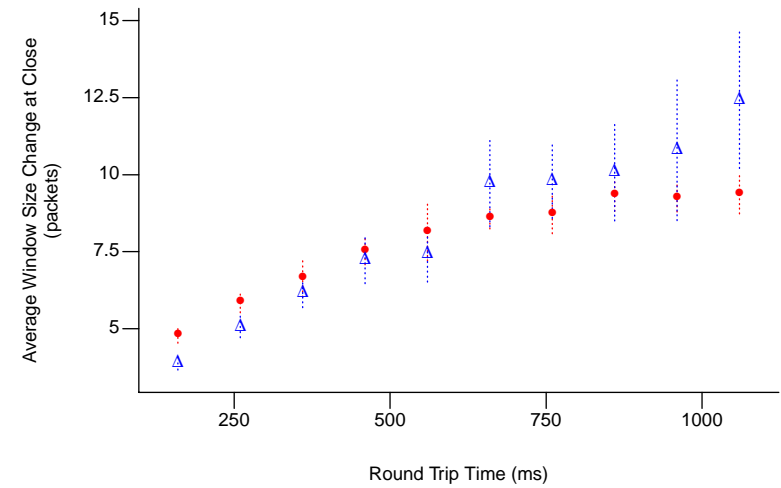
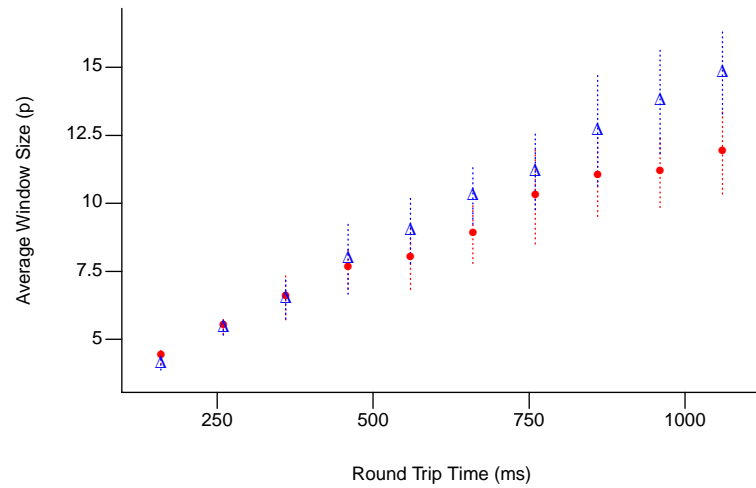

## Simulation Conclusions

- At High BW-Delay Product, ACC:
  - Adjusts Each Window Less Frequently
  - Adjusts Each Window A Larger Amount
  - Each Source Keeps Larger Window Longer
- At Lower BW-Delay Product, Over-control
- Best Improvement: **20%+**



## Implementation

- Implement ACC In The ISI ASP AN Environment
- Leverage ASP Development Work
- Advance Development of ASP
- Implement Transport (RDP) To Test Ideas



## RDP Status

- Reliable Packet Transport Functions
- Incorporates TCP-like Congestion control
  - Fast Retransmission
  - Slow-Start
  - Congestion Avoidance
- Performance Acceptable (in Java!)
- Next Step: Activation



## Why an Active RDP?

- Simpler than TCP – concentrate on ACC
- Take advantage of AN
  - Virtual Networking (some risk, too)
  - Active Code Loading
  - Improve Environment
  - Simplify Filtering
- RDP Is The Only General Reliable Active Transport

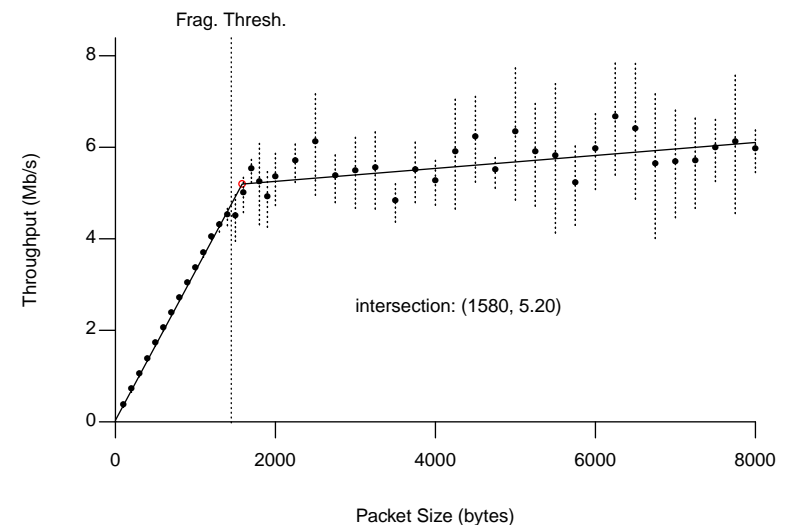



## Conclusions

---

- If AN Works, Feedback Congestion Control Can Benefit
  - ACC Shows Improves Throughput Max 20%
  - Possibility Of Tuning Algorithms Further
- ACC Will Be Tested in a Real AN Environment
  - RDP Being Activated in ASP



## For More Information

---

- My Home Page:  
<http://www.isi.edu/~faber/>
- ACC Home Page:  
<http://www.isi.edu/active-signal/ACC/>
- ARP Home Page:  
<http://www.isi.edu/active-signal/ARP/>
- ISI AN Home:  
<http://www.isi.edu/active-signal/>